



|||||
EUROTEC
|||||

QUALITY HEAT EXCHANGERS

Contact

T: +39 035 4541161 **F:** +39 035 459045

E: info@eurotecsrl.it

W: www.eurotecsrl.it

Via Fiume Po, 192 24040 Stezzano (BG) Italia

Via Artigianato, 11 26833 Merlino (LO) Italia



to access our sitoweb



EUROTEC
QUALITY HEAT EXCHANGERS

EUROTEC

QUALITY HEAT EXCHANGERS

ABOUT US

Eurotec srl is a company founded in 2007 operating in two plants both of 2,500 square meters modern and functional, one located in the industrial area of Stezzano 3 km from Bergamo dedicated to production for our geometries P2510-P3016-P4016-P6016 and the other is located in Merlino in the province of Lodi for geometries P3012-P3512.

We offer finned pack heat exchangers for heating, cooling, condensation, evaporation, steam and heat recovery.



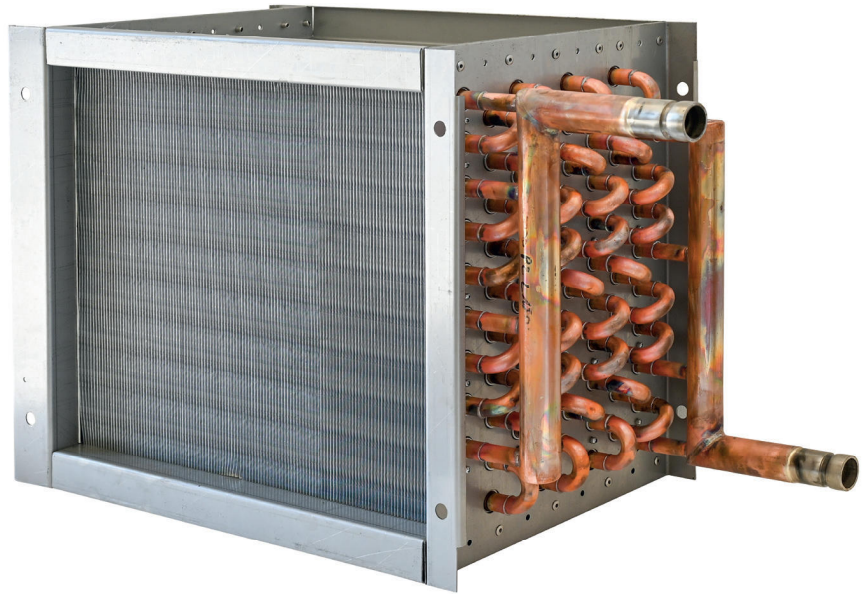

***HEAT EXCHANGERS MADE
TO MEASURE FOR YOU***

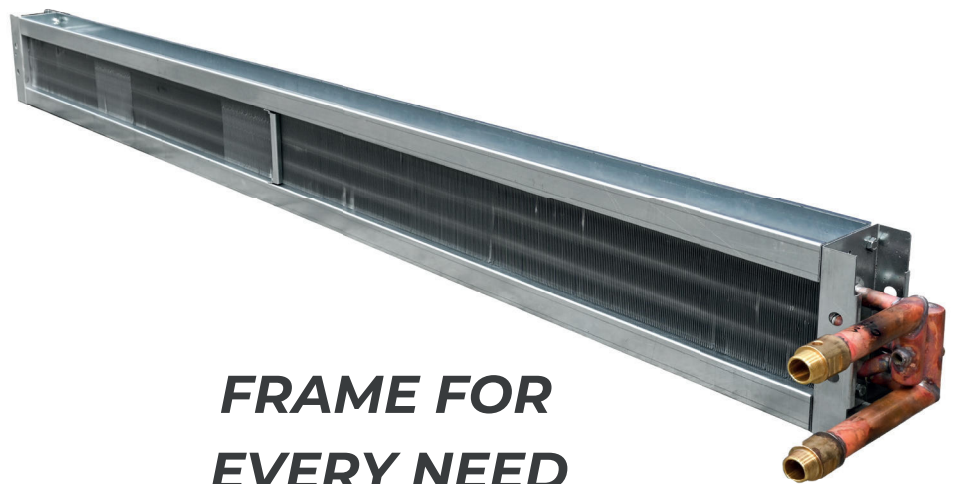

***FRAME FOR
EVERY NEED***

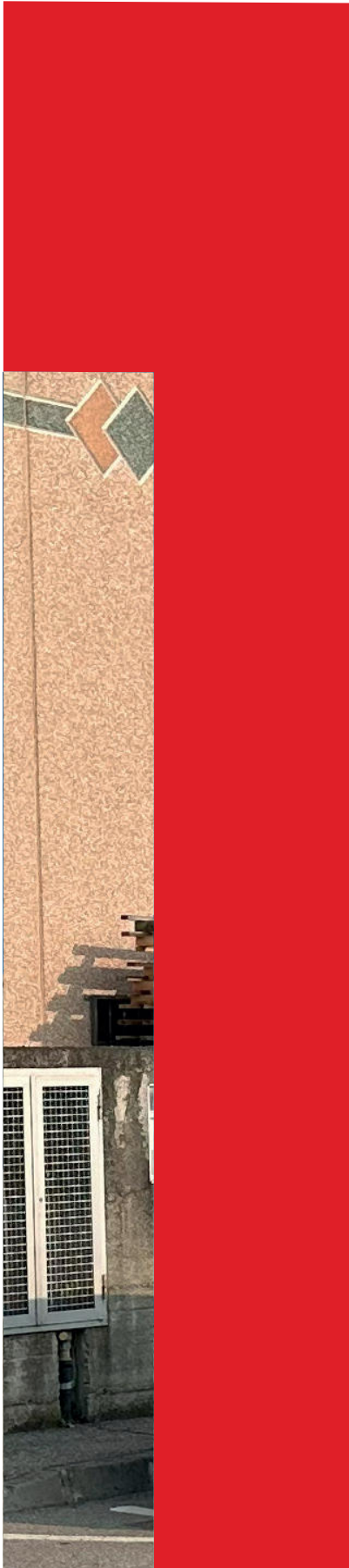

APPLICATIONS:

TERTIARY SECTOR:

AIR CONDITIONING SYSTEMS FOR NAVAL AND OFFSHORE APPLICATIONS, PHARMACEUTICAL SECTOR, HOTELS, THEATRES, SUPERMARKETS, OFFICES, HOSPITALS, LARGE KITCHENS, BANKS, SWIMMING POOLS ETC.

INDUSTRY:

SYSTEMS OF VENTILATION AND PROCESS AND ROOM AIR CONDITIONING.

FOOD & AGRICULTURE:

INSTALLATIONS FOR DRYING AND STORAGE.



EUROTEC HAS ISO 9001 CERTIFICATION.

The German certification body TU confirms that the ISO standard has been applied in a manner that creates maximum customer satisfaction with regard to delivery times, levels of service and compliance with contract terms. The internal Quality Department supervises every stage of the process, from the heat exchanger de-sign to the selection of suppliers and raw materials, from careful monitoring of construction to the rigorous 21-stage final testing, the results of which are reported on the QC label of every product.

The company conducts an annual self-assessment by means of an internal audit of every business area and a system of digital tracking and control that performs real-time health checks of the production unit.



***The highest
customer satisfaction in
terms of product quality
and service.***



THE STANDARDS

EUROTEC

1. Maximum production flexibility, with the ability to supply single units.
2. Timely production and delivery of reliable products.
3. Technical Office and R&D Department at the service of customers for the development of tailor-made solutions and technologies.
4. Logistics support: collaboration with international carriers for management of orders and shipments to meet customer needs.
5. Intuitive proprietary software for thermodynamic calculation, continuously updated for maximum ease of use. It is available as a desktop application and in version(.DLL) for integration into UTA configuration software.



*Scan the QR code to download it
after installation contact our offices
for activation.*

MAIL: info@eurotecsrl.it

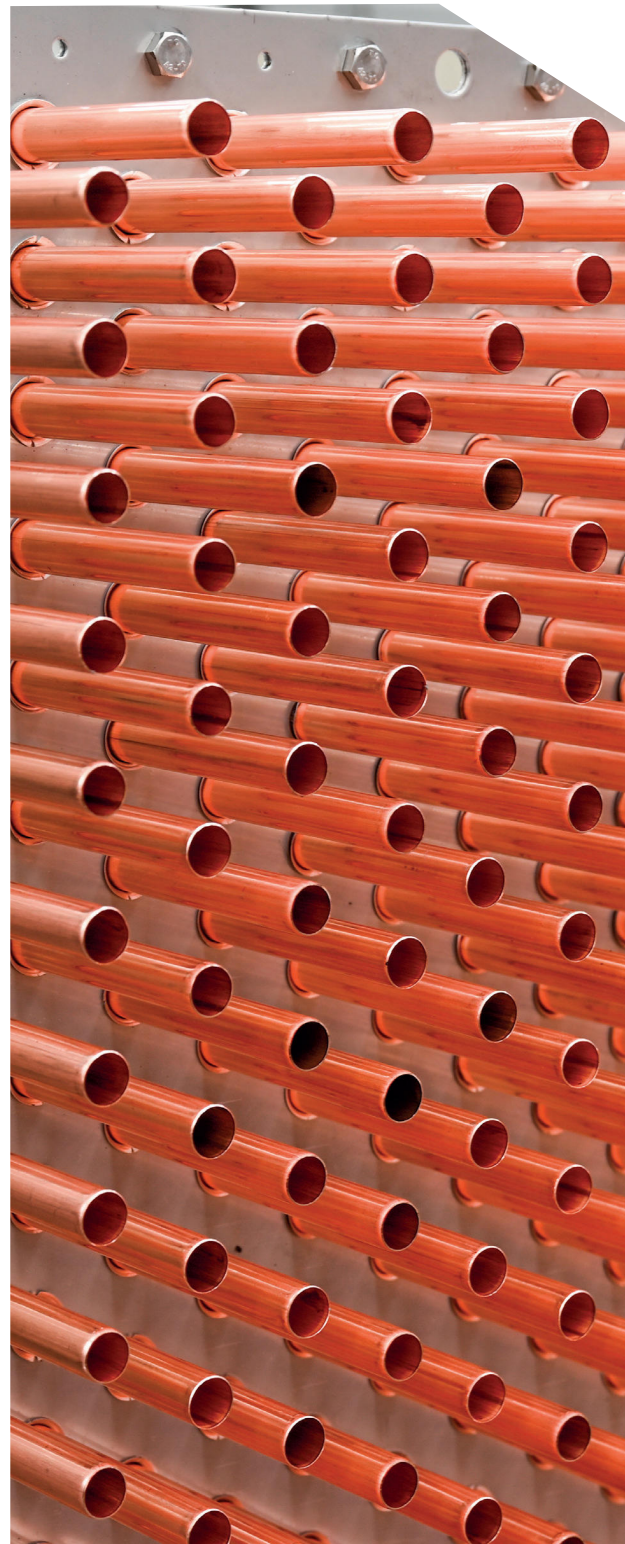

OUR VALUES

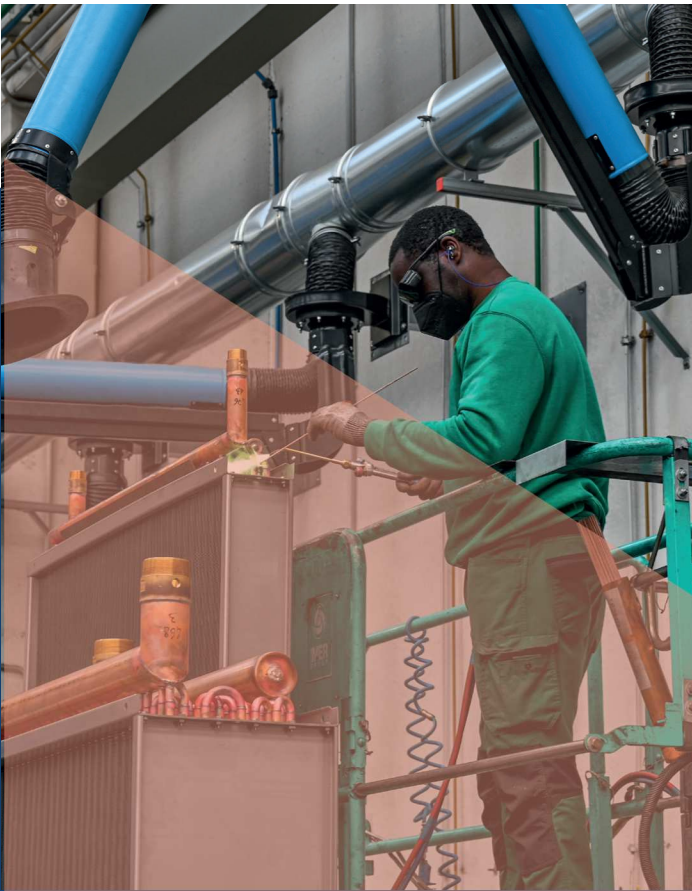

THE VALUES

Regular staff training, continuous monitoring of production and success in obtaining relevant certification are evidence of our determination to excel.

The technical office is always at the service of customers to respond to any need or to assess the viability of customised products. We can also provide clients with software for the thermodynamic calculation of our exchangers.



**A WIDE RANGE OF PRODUCTS OF ALL
SIZES AND RANKS**

6 CHOICES OF GEOMETRY FOR ALL REQUIREMENTS

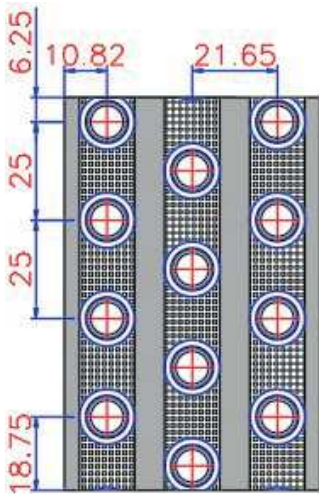

P2510: PYRAMIDAL Fin

- PIPE Ø9,52mm
- TRIANGULAR SHAPE

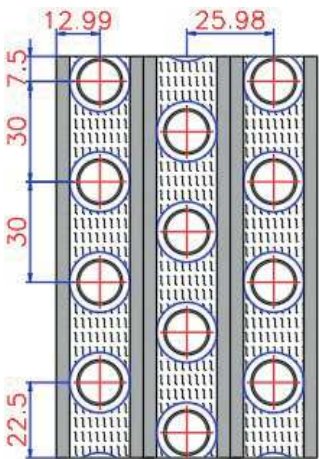

P3012: LOUVERED Fin

- LOUVERED FIN
- V-WAFFLE FIN
- PIPE Ø12mm
- TRIANGULAR SHAPE

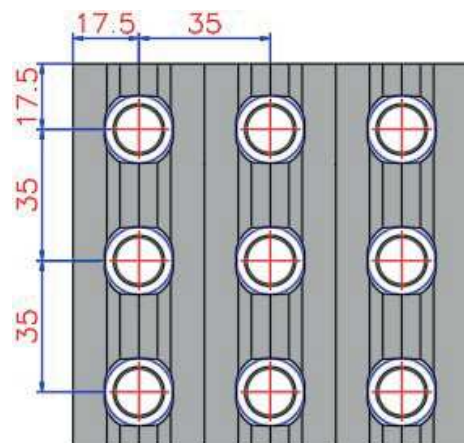

P3512: V-WAFFLE Fin

- V-WAFFLE FIN
- PIPE Ø12mm
- SQUARE SHAPE

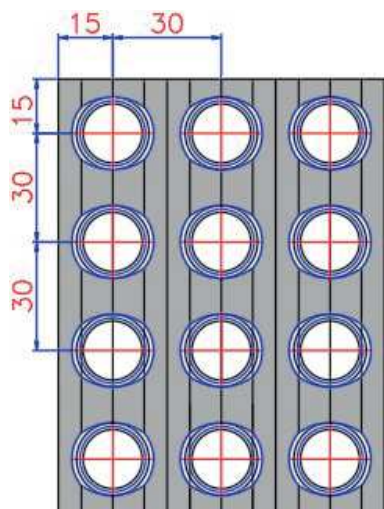

P3016: V-WAFFLE Fin

- V-WAFFLE FIN
- PIPE Ø15,88mm
- SQUARE SHAPE

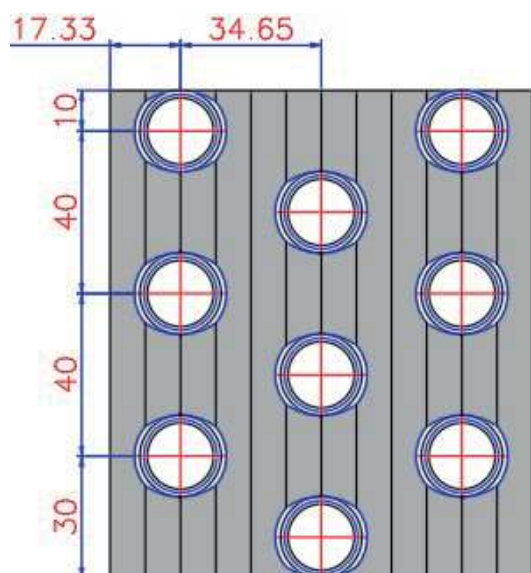

P4016: V -WAFFLE Fin

- V-WAFFLE FIN
- PIPE Ø15,88mm
- TRIANGULAR SHAPE
- RESISTOR HOLES
- Ø9,4mm

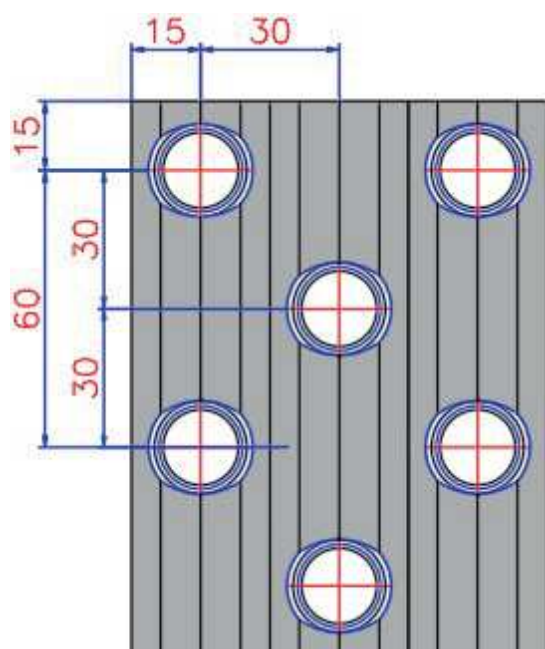

P6016: -WAFFLE Fin

- V-WAFFLE FIN
- PIPE Ø15,88mm
- TRIANGULAR SHAPE

MNEMONIC CODES

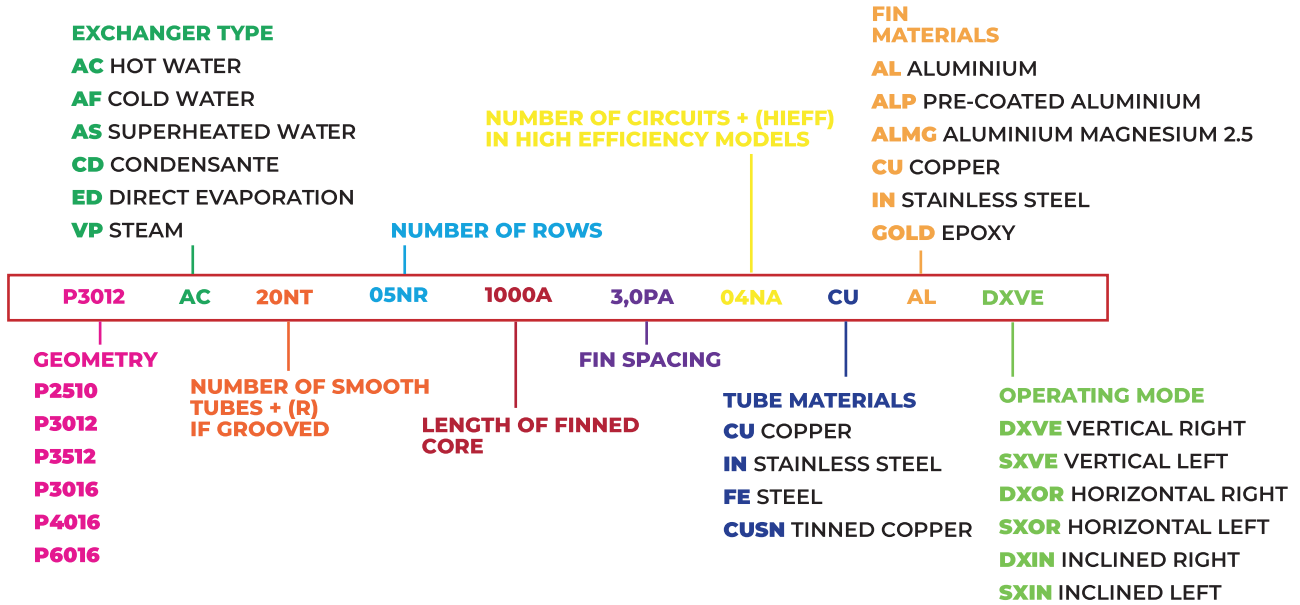

SPECIFICATIONS TECHNIQUES

Tubes and Frame Material (mm)	Expanded Tube		P2510	P3012	P3512	P3016	P4016	P6016
	ØExternal	ØInternal						
ØExternal	Ø10,12	Ø9,52	x					
Copper - Ø9,52 x 0,50	Ø10,12	Ø9,52	x					
Copper - Ø12 x 0,32	Ø12,60	Ø11,96		x	x			
Copper - Ø12 x 0,50	Ø12,60	Ø11,6		x	x			
Copper - Ø12 x 0,70	Ø12,60	Ø11,2		x	x			
Copper - Ø15,88 x 0,38	Ø16,48	Ø15,72				x	x	x
Copper - Ø15,88 x 0,50	Ø16,48	Ø15,48				x	x	x
Copper - Ø15,88 x 0,70	Ø16,48	Ø15,08				x	x	x
Copper - Ø15,88 x 1,00	Ø16,48	Ø14,48				x	x	x
Grooved Copper - Ø9,52 x 0,50	Ø10,12	Ø9,12	x					
Grooved Copper - Ø12 x 0,50	Ø12,60	Ø11,60		x	x			
Frame Material	GALVANIZED - STAINLESS 304 AND 316 - ALUMINIUM - BRASS - COPPER							

Fins Material-Alloy-Thickness	Fin spacing (mm)					
	P2510	P3012	P3512	P3016	P4016	P6016
Aluminium - 8006 - 0,10	1,6 - 3,0	1,6 - 3,8	1,6 - 3,5	1,6 - 3,0	1,6 - 3,8	1,6 - 3,5
Aluminium - 8006 - 0,20	1,6 - 5,0	1,6 - 5,0	1,8 - 8,0	1,6 - 3,9	1,6 - 6,0	1,6 - 6,3
Aluminium - 8006 - 0,25	NO	NO	1,8 - 8,0	NO	1,6 - 4,0	NO
Aluminium - 8006 - 0,40	NO	NO	NO	NO	2,0 - 5,0	NO
Pre-painted Al. - 8079 - 0,12	1,6 - 3,5	1,6 - 3,5	2,0 - 5,0	1,6 - 3,0	1,6 - 4,0	1,6 - 4,0
AlMg 2,5 - 5052 - 0,18 mm	NO	1,6 - 4,0	2,0 - 5,0	1,6 - 3,0	1,6 - 4,2	1,6 - 3,5
Antimicrobial Al. - 8079 - 0,12	NO	NO	1,6 - 3,5	1,6 - 3,0	1,6 - 4,0	1,6 - 4,0
Epoxy Gold Al. - 8079 - 0,20	1,6 - 4,0	1,6 - 4,5	2,0 - 7,0	1,6 - 3,3	1,6 - 5,5	1,6 - 4,5
Copper - 0,10	1,6 - 3,5	1,6 - 4,0	1,6 - 3,5	1,6 - 3,0	1,6 - 3,5	1,6 - 3,5
Copper - 0,20	1,6 - 5,0	NO	NO	1,6 - 3,5	1,6 - 6,0	1,6 - 5,8

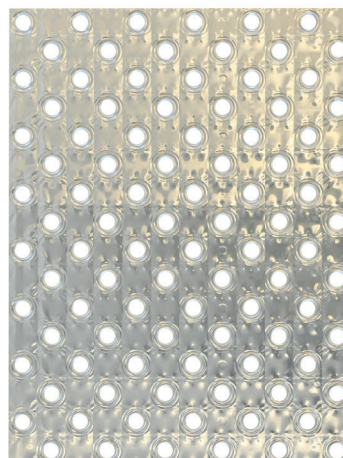
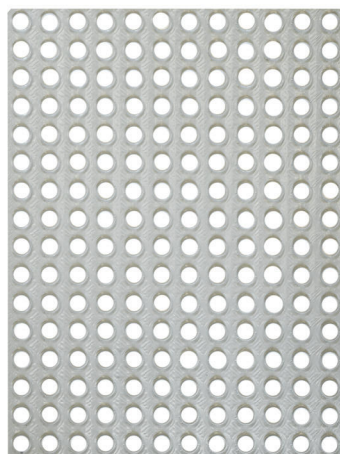
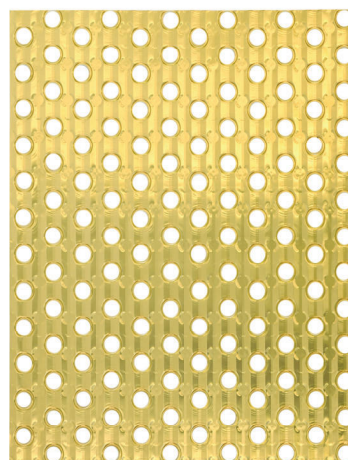
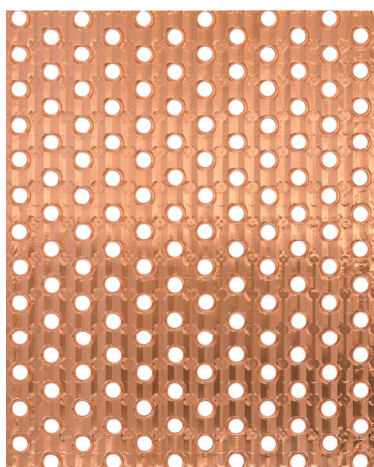

RECOVERY BATTERIES

HIGH EFFICIENCY

Recovery coils are designed with a different design than a standard water coil, it is a high performance heat exchanger to be able to achieve 68% efficiency as required by the ErP Directive.

Recovery coils have a dedicated circuit of vents and drains that allows it to work 100% countercurrent for maximum energy transfer, have thick and widely spaced fins to have low pressure drops and promote cleaning over the entire depth of the finned pack

Scan the QR code to download it after installation contact our offices for activation.

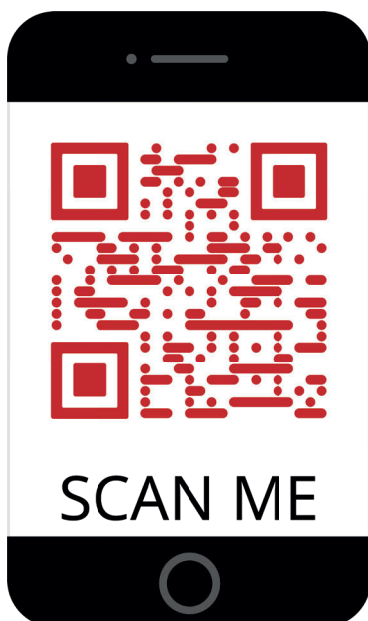

MAIL: info@eurotecsrl.it



CLOSED LOOP CIRCUITS

Modern air conditioning systems should reduce energy consumption and operating costs. Closed-loop recovery systems are one of the ideal solutions especially for retrofit projects, in buildings with complex ducts and energy sources spaced far apart. Closed-loop loops use one or more recovery exchangers most often located within the supply and exhaust air streams of an air handling system, or in the exhaust gases of an industrial process. These exchangers are connected to each other through a separate circuit of hydraulic piping, where by means of a pump some fluid generally glycol water is circulated, which takes heat from the exhaust coil air stream and gives it to the supply coil air.

This type of system is only for sensible heat transfer. Because the two air flows are separate, there is no risk of exhaust gas contamination, this makes them suitable for uses such as: hospitals, operating rooms, clean rooms, food laboratories where very high requirements for hygiene are demanded.

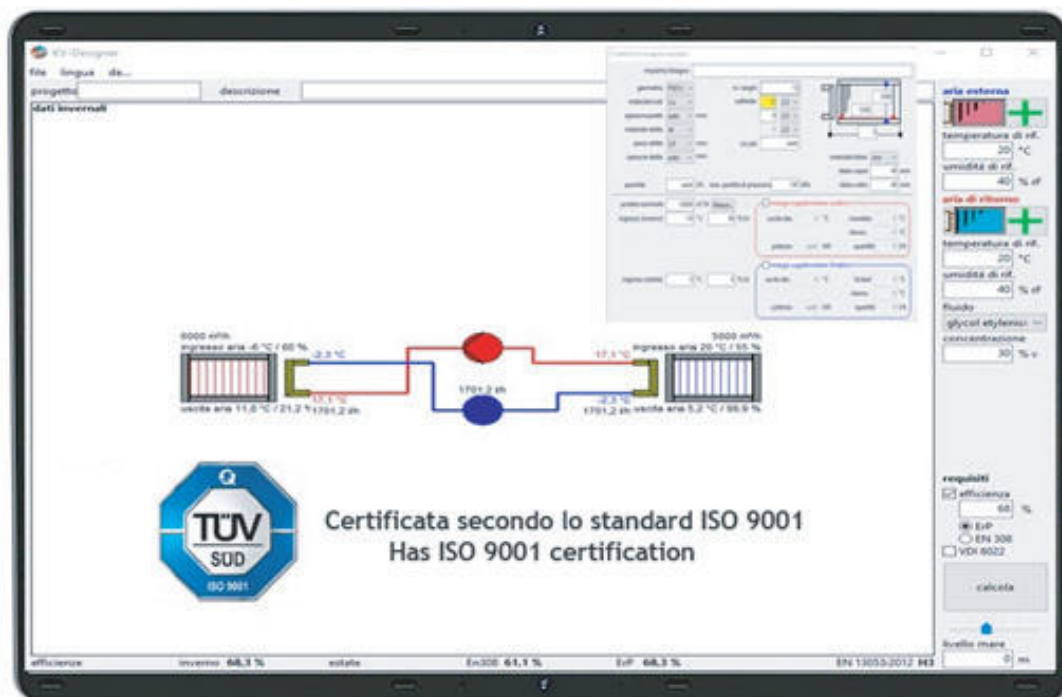

We have software certified by the TUV certifying body that guarantees compliance with the criteria of the ErP directive and the processing of the correct calculation of our recovery exchangers.

OUR ACCESSORIES

**01**

CONDENSATE TRAY

We can provide custom-made condensate tray, gives place at the bottom of the exchangers or in intermediate positions on the height of the coil. They can be made of galvanized sheet metal or stainless steel 304 or 316.



*A solution for every
need*

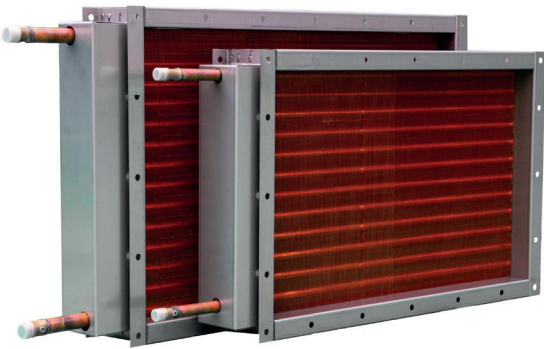

02

CASING AND CHARACTERERISTICS CONSTRUCTION

We can also provide protective covers on the bends and manifolds side,drill holes or apply threaded inserts. They can be made of galvani-zed sheet metal or stainless steel 304 OR 316.

03

DROPLET SEPARATOR

Our custom-made droplet separator consists of a frame that can be fabricated from different types of materials such as: stainless steel 304 or 316, galvanized sheet metal, and aluminum. We use the DH2500 profile made of talc-reinforced polypropylene, which makes it usable in different operating conditions, suitable for vertical mounting in a horizontal airflow, with frontal velocity between 2 m/s and 5 m/s and maximum temperature 100°C. The profiles are spaced with 33mm pitch that ensure low pressure drop levels and high separation efficiency. Used for cooling coils, they serve to prevent entrainment of droplets formed by condensed moisture when air velocity is high.

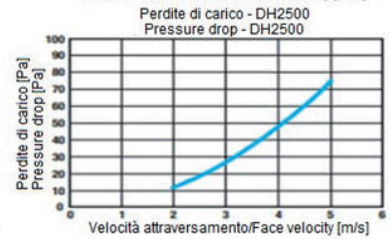
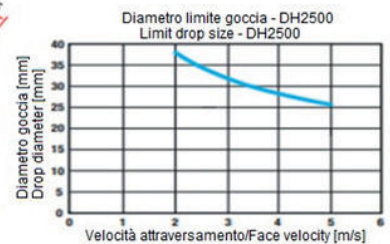
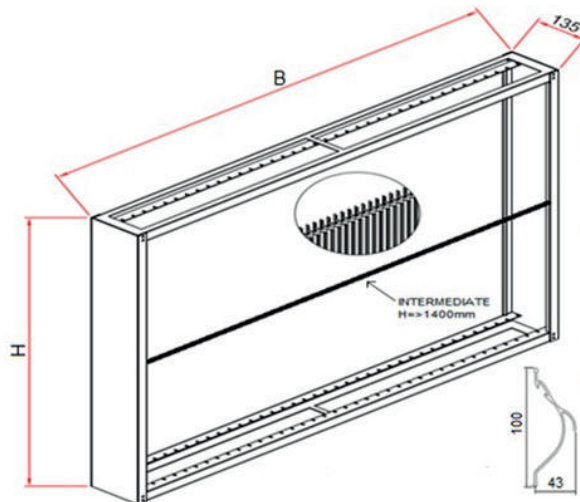
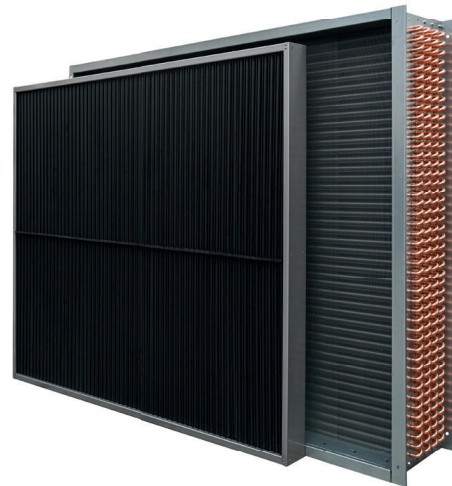

PROTECTIVE TREATMENTS

BLYGOLD®



Blygold® is a polyurethane coating containing aluminium pigments. It gives long-lasting protection without reducing efficiency or causing loss of pressure, and can be applied during manufacture or on site. A thin coating of Blygold® ensures good heat exchange and a high level of chemical protection.

When applied by certified operators working to Blygold specifications, PoluAl XT is extremely effective at preventing damage to air conditioning systems and curbing excessive energy consumption.

Corrosion resistance (ASTM B117): 4,000 hours.

HERESITE®



This is an anticorrosive coating containing thermosetting phenolic resins for special applications requiring complete covering of the heat exchanger.

It provides high corrosion resistance in marine and saline environments and is effective against a wide variety of corrosive fumes, chemicals and condensates. Heresite® coating is widely used in the HVAC-R sector, extending the life span of heat exchangers, coils and other devices that treat air and smoke containing particles of light metals.

Corrosion resistance (ASTM B117): 6,000 hours.

THERMOGUARD® Thermoguard® has developed Finguard Silver SB for protecting heat exchangers.



This polyurethane coating with aluminium pigments protects against saline environments, chemical agents (resistance table available) and UV radiation.

Finguard Silver SB is applied by spraying performed by certified operators both in the factory and on site.

Corrosion resistance (ASTM B117): 3,000 hours.

Colour: silver.

TIN-COATING



Tinning is an electrolytic immersion treatment used to protect metals such as copper, iron, aluminium and their alloys.

Compact tin coatings are widely used for protection against atmospheric agents, water, solutions and many other substances, including foodstuffs.

In addition to high corrosion resistance, tinning gives visual appeal and very high electrical conductivity.

ELECTROFIN® E-COAT



This is an ideal anti-corrosion treatment, applied by immersive cathodic electrodeposition. It can be customised with specific chemical formula to match the technical characteristics of each heat exchanger, and is effective in marine and industrial environments.

The consistency and uniformity of Electrofin® E-Coat provides protection against a wide range of corrosive chemical fumes. Guaranteed for 5 years.

Corrosion resistance (ASTM B117): 6,000 hours.

CATAPHORESIS



This electrodeposition process is recommended for creating a primer coat on the surfaces of elements made of iron, steel and other alloys. It offers excellent resistance to atmospheric corrosion and other forms of attack, and improves the adhesion of powder coatings. This type of coating has poor resistance to UV exposure, and is therefore not suitable for use in direct sunlight.

THE PRODUCTION PROCESS

01

THE FRAME

The frame is made of galvanised sheet steel, 304/316 stain-less steel, copper, aluminium, brass or descaled steel plate, and is made in such a way that the fins and bends are well protected.

The tube holes in the tube plate are fitted with collars made of the same material as the fins, which allow the tubes to move freely in order to prevent thermal expansion causing cuts and breakages.

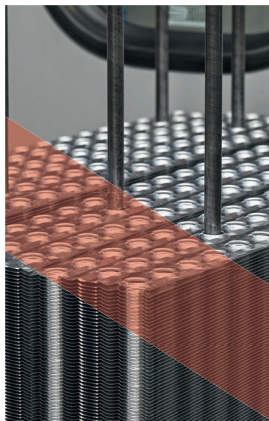

THE FINNED CORE

The finned core is made from materials that can be selected in our calculation program. The fins are fitted with a collar of variable height enabling fin spacing to be controlled. Fin surfaces are corrugated to increase stability and to generate air turbulence for a higher heat exchange coefficient. This type of surface also prevents dust accumulating inside the finned core and helps to disperse condensation.

02**03**

TUBES

We use tubes of various diameters and internal finishes to construct the most appropriate heat exchangers for user requirements. Tin-plated tubes have anticorrosive properties while grooved tubes provide much better energy exchange than those with smooth inner surfaces. A hairpin-bender is used to make tubes for exchangers with a finned length of up to 4,000 mm, and a pipe straightener for greater lengths. Eurotec takes great care during mechanical expansion of the tubes, which must be in perfect contact with the fins for optimal heat exchange

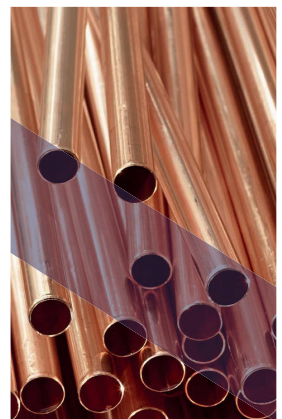

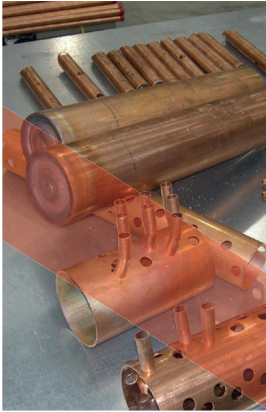
**HEADERS****04**

The headers of the exchangers, produced in-house, are made of copper in a work centre equipped with a latest generation tube-end closing machine. The ends of the headers are shaped appropriately for the way in which the heat exchanger will be used.

05**WELDING**

EUROTEC employs certified braze welding operators. Braze welding is a process that enables the joining of various types of metal materials and is based on the melting and solidification of the filler material alone.

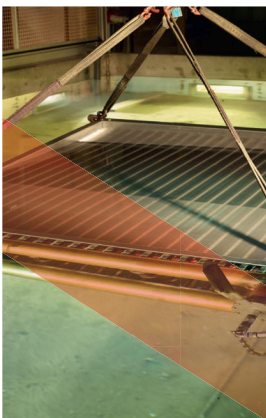
**TEXTING****06**

All our heat exchangers undergo rigorous sealing tests before delivery. Eurotec tests all its products in a tank at pressures ranging from 20 to 55 bar. All freon exchangers are delivered hermetically sealed and charged with nitrogen.

07**PACKAGING**

For standard shipments we provide custom-made pallets, on which the product is properly secured and packed. Upon request, we can provide protective wooden cages, with the possibility of also adding ISPM15 FAO treatment for export.

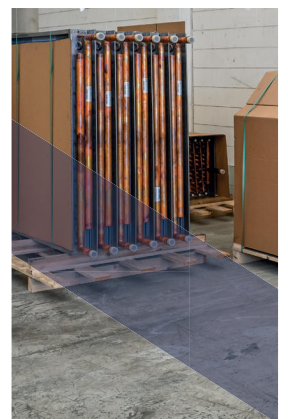

MARKETS AND SECTORS

APPLICATION AREAS FOR EUROTEC PRODUCTS

*With years of experience
and a highly professional
approach,
EUROTEC operates in a
range of markets and
sectors.*

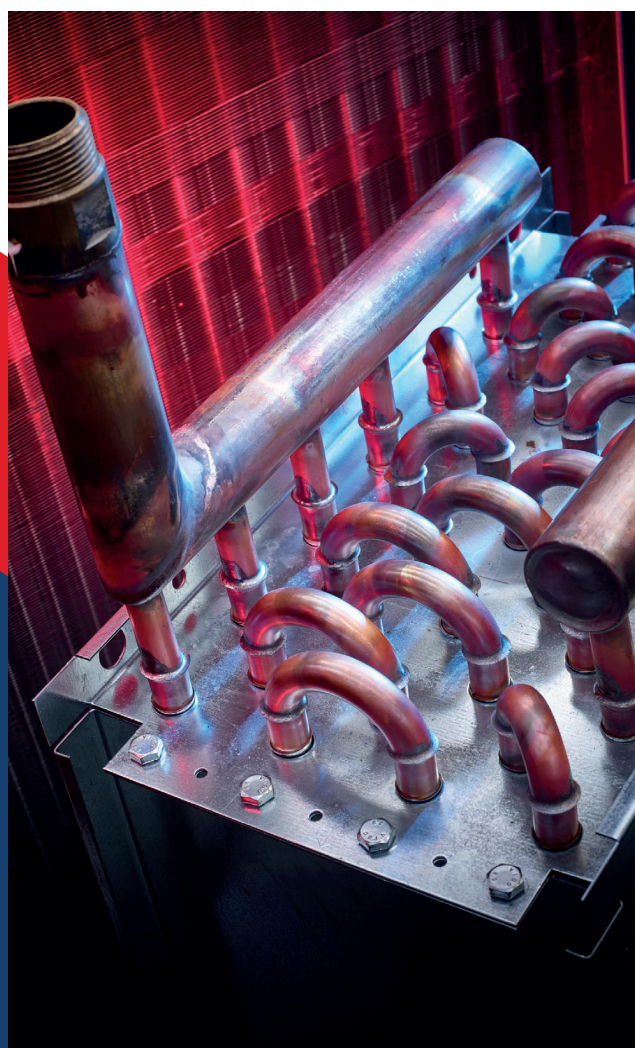



Naval

Production of heat exchangers for naval and offshore industries with references from cruise ship companies.



Hospitals

Heat exchangers with various performance characteristics and in various materials to maintain hygiene and reduce bacteria levels.



Shopping Centres

High efficiency energy recovery systems developed with our proprietary software, comprising either a supply and return exchanger or multiple exchangers, with elimination of contamination between the two flows.



Automotive

Cooling of commercial vehicles, preheating of fluids, air conditioning and refrigeration of vehicle and train interior.

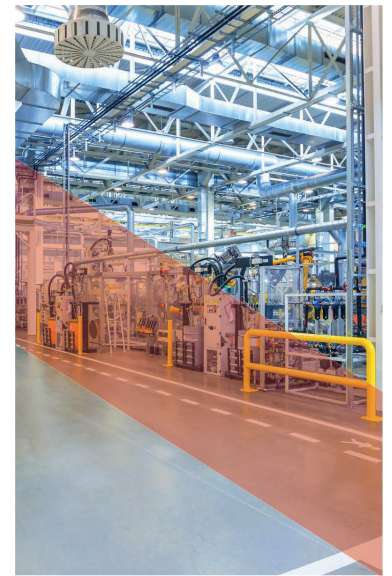

Food Production

Drying, pasta-making, curing and preservation equipment.

WHY CHOOSE EUROTEC



HIGH-TECH MANUFACTURING MACHINERIES



COMMERCIAL RELIABILITY



THOROUGH AFTER-SALES SERVICE



MAXIMUM AVAILABILITY AND FLEXIBILITY



QUALITY CHECK ON ALL THE PRODUCTION LINE



WIDE RANGE OF PRODUCTION MATERIALS



EXCELLENT QUALITY/PRICE RATIO



6 AVAILABLE GEOMETRIES



THE MAXIMUM SATISFACTION OF OUR CUSTOMERS OUR MISSION.



Thank you

***PEOPLE, PRODUCT QUALITY
AND CUSTOMER CARE ARE
OUR VALUES.***